

Two-Way Diverter Valve WHK

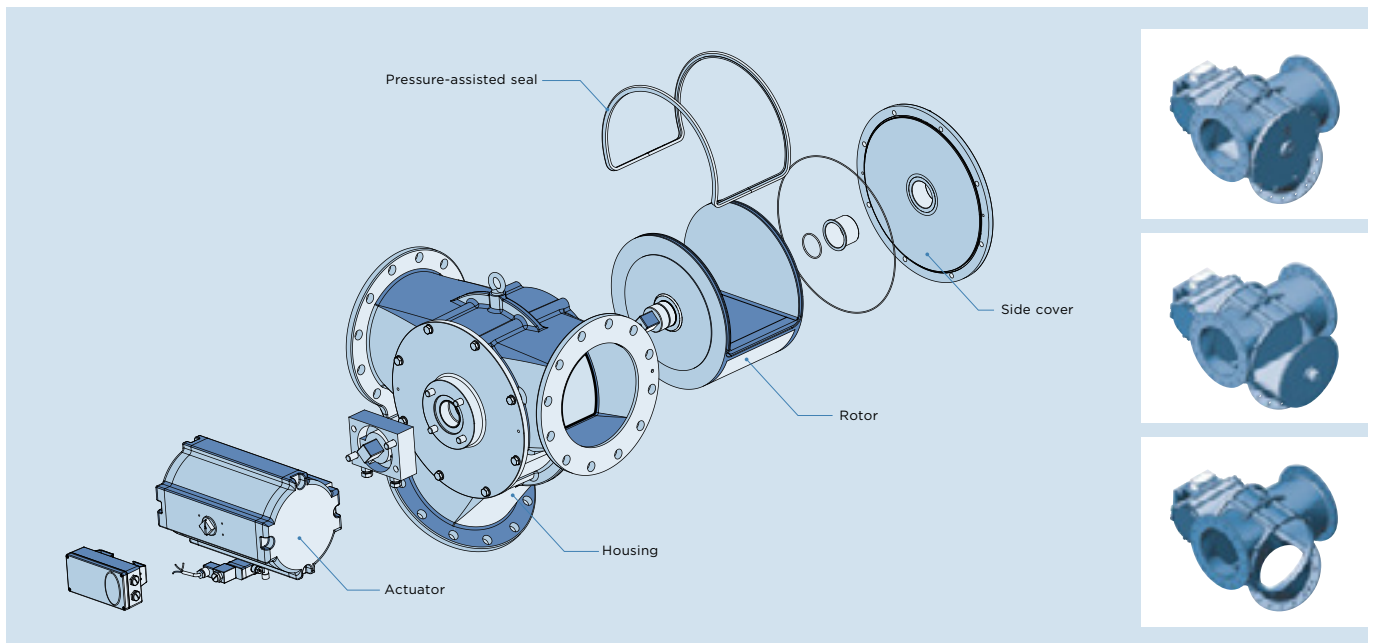

COMPACT SINGLE CHANNEL DIVERTER VALVE FOR GRANULAR PRODUCTS AND POWDERS

- _ With sealed rotor and 45° outlet
- _ For compact installation in conveying lines or gravity pipes up to 3 barg



Straight through

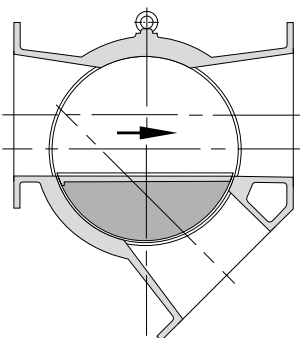

Diverted

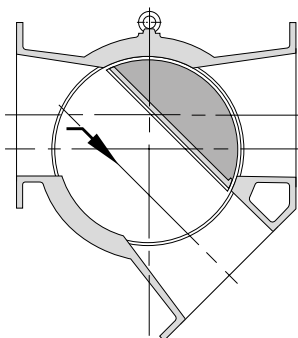

DIVERTER VALVE FOR GRANULAR PRODUCTS AND POWDERS | WHK

MAX. PRESSURE	3 barg (43 psi) system and differential pressure
OPERATION TEMPERATURE	-20 °C to 100 °C
APPLICATION	Suitable for fluid group 2 in accordance with PED (fluid group 1 upon request)
SEAL CONFIGURATION	Endless wrap-around seal
MATERIAL	Stainless steel

OPTIONS AND ACCESSORIES

- _ Can be used in ex-zones with proper accessories
- _ Actuator on the left or right side
- _ Quick cleaning design
- _ Wash water design for draining water out of silos, for example

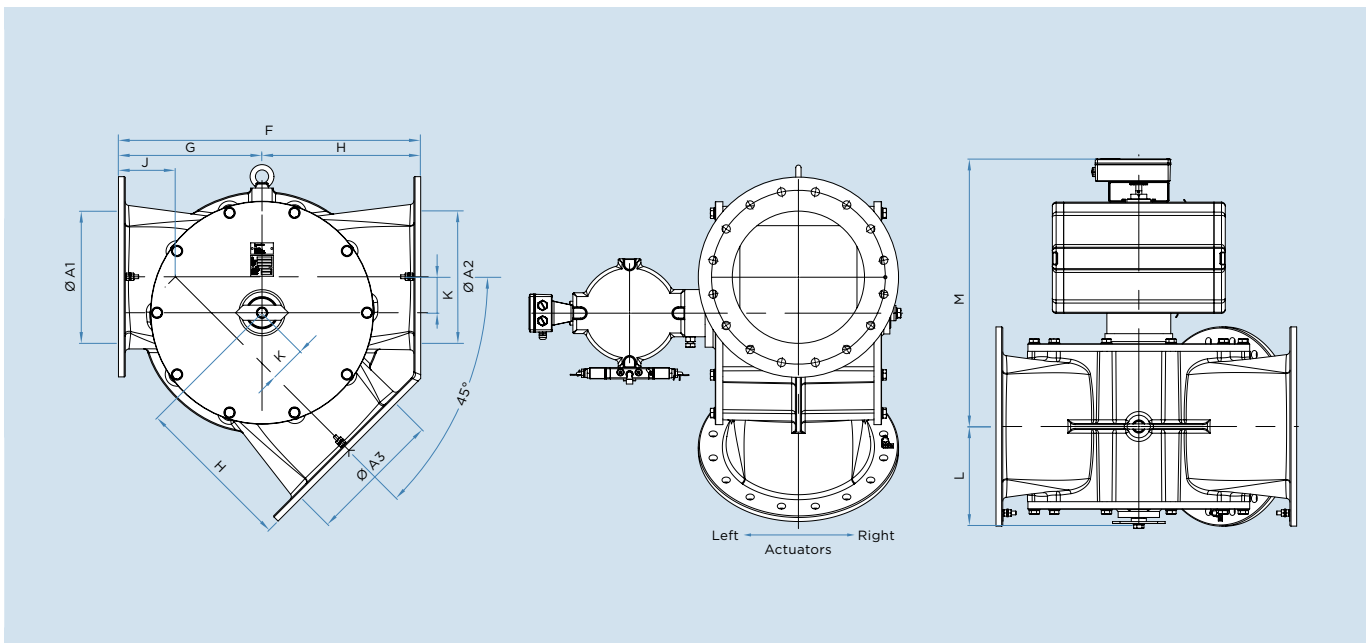

	Inlet*/Outlet*			Other dimensions										Weight (appr. kg)	
	A1/A2/A3 (DIN)	A1/A2/A3 (ASME)	Ø A1	Ø A2	Ø A3	F	G	H	J	K	L	M	AC	SS	
WHK 150	DN 150	6"	162	162	162	460	220	240	109	46	152	453	-	100	
WHK 200	DN 200	8"	212	212	212	530	250	280	112	57	180	529	91	165	
WHK 250	DN 250	10"	265	265	265	680	340	340	161	74	216	630	162	220	
WHK 300	DN 300	12"	316	316	316	750	355	395	150	85	250	657	205	348	
WHK 350	DN 350	14"	350	355	355	800	380	420	151	95	271	713	-	450	
WHK 400	DN 400	16"	406	406	406	900	420	480	153	110	300	781	-	700	

Dimensions in mm

* Drilled according to DIN PN 10 or ASME 16.5 class 150.